



DITEK Corporation
 ONE DITEK CENTER
 1720 Starkey Road
 Largo, FL 33771

INSTALL INSTRUCTIONS

DTK-LVLP SERIES

NOTICE: This SPD should be installed and grounded, by a licensed contractor, per the applicable requirements of the NEC and the following instructions. These devices are only to be installed on communication loop circuits which have been isolated from the Public Switched Telephone Network.

APPLICATION

Surge suppression for data circuits, isolated loop circuits, or low voltage telecommunications using a screw terminal connection.

INSTRUCTIONS:

Caution: Measure all voltages to ensure applied voltage does not exceed the voltage rating of the unit. Improper installation voids the warranty.

1. Disconnect power to the circuit.
2. The surge protector must be connected in series with the wiring of the equipment to be protected.
3. Securely mount the unit using the double-sided tape (supplied), or two #8 screws (not supplied).
4. Terminate the field wiring to the "IN" side of the surge protector.
5. Terminate the supply wiring from the equipment to the "OUT" side of the surge protector.
6. Allow the surge protector enough reaction time by providing a minimum of 3 feet of wire distance between the "OUT" side of the surge protector and the equipment being protected.
7. Ground the surge protector using a minimum 14AWG solid or stranded ground wire.
8. If multiple surge protectors are installed on the same circuit, use a common ground source to eliminate the possibility of a difference in ground potential.

Ground Resistance Rule: Maximum ground resistance is 25 Ohms, 5 Ohms or less is optimum. This cannot be an assumed value and must be measured to ensure proper grounding.

9. After all connections have been made and no hazards exist, restore power to the circuit.

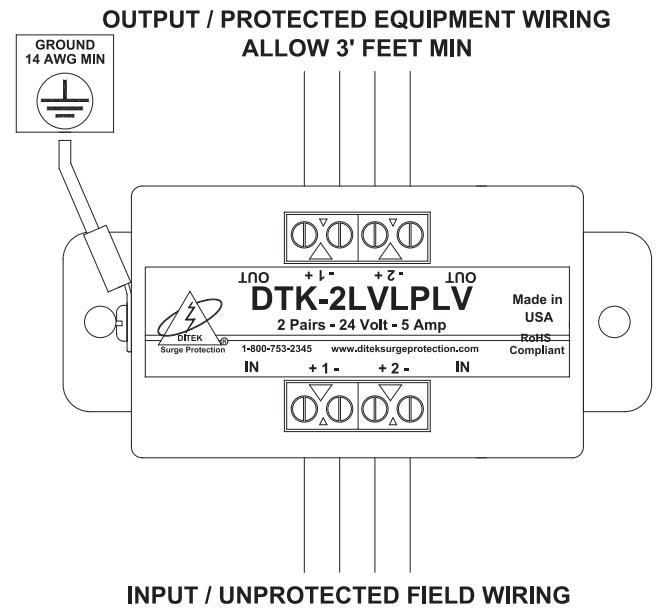
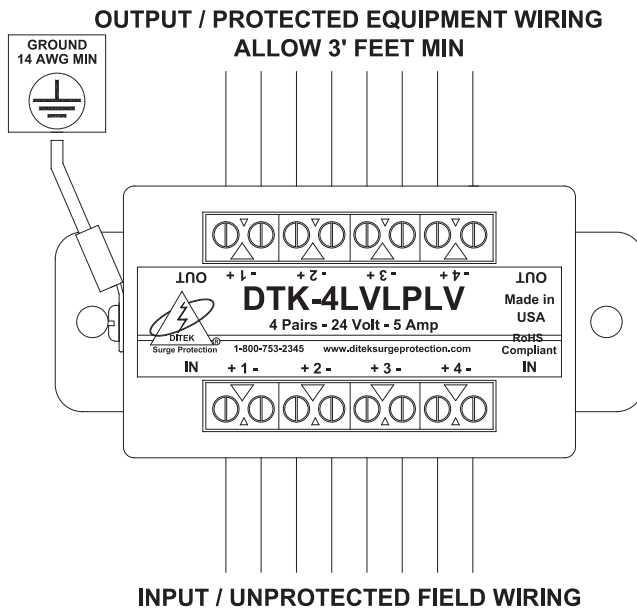

MODEL	SERVICE VOLTAGE	CLAMPING VOLTAGE
DTK-2LVLPD / DTK-4LVLPD	5V	8V
DTK-2LVLPX / DTK-4LVLPX	12V	22V
DTK-2LVLPF	24V	39V
DTK-2LVLPV / DTK-4LVLPV	24V	39V
DTK-2LVLPVOPX / DTK-4LVLPVOPX	48V	76V
DTK-2LVLPVPRUV / DTK-4LVLPVPRUV	130V	155V

INSTALLATION