

DTK-2MHTP (2-Pair Modular Hybrid Line Protector)

Note: Connect this device in series between the field wiring and the alarm panel supply wiring.

1. Connect the communication loop circuit from the field to the side marked INPUT. The first pair is connected to the terminals marked 1+ and 1- . If a second pair is used, connect to the terminals marked 2+ and 2- .
2. Connect the communication loop for the alarm panel supply wiring to the side marked OUTPUT.

DTK-2MHLPPXB (2-Pair Modular Hybrid Line Protector)

Note: Connect this device in series between the field wiring and the alarm panel supply wiring.

1. Connect the IDC (Initiating), NAC (Notifying), or SLC (Signaling) circuit wiring from the field to the side marked INPUT. The first pair is connected to the terminals marked 1+ and 1- . If a second pair is used, connect to the terminals marked 2+ and 2- .
2. Connect the IDC (Initiating), NAC (Notifying), or SLC (Signaling) alarm panel wiring to the side marked OUTPUT.

Note: This module may be used for protection of any IDC (Initiating), NAC (Notifying), or SLC (Signaling) circuits. Each module will protect 2 pairs of the same circuit.

Note: All modules have been factory pre-wired for ground. It is not necessary to make any additional ground connections.

After all connections have been made and no hazards exist, restore power

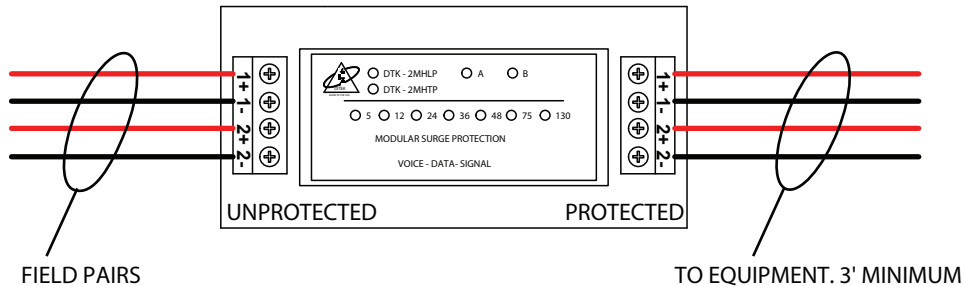

191520 INT-100088-001 Rev 6

DITEK CORPORATION

One DITEK Center 1720 Starkey Road Largo, FL 33771
1-800-753-2345 www.ditekcorp.com



DTK-TSS2

Total Surge Solution

User Guide

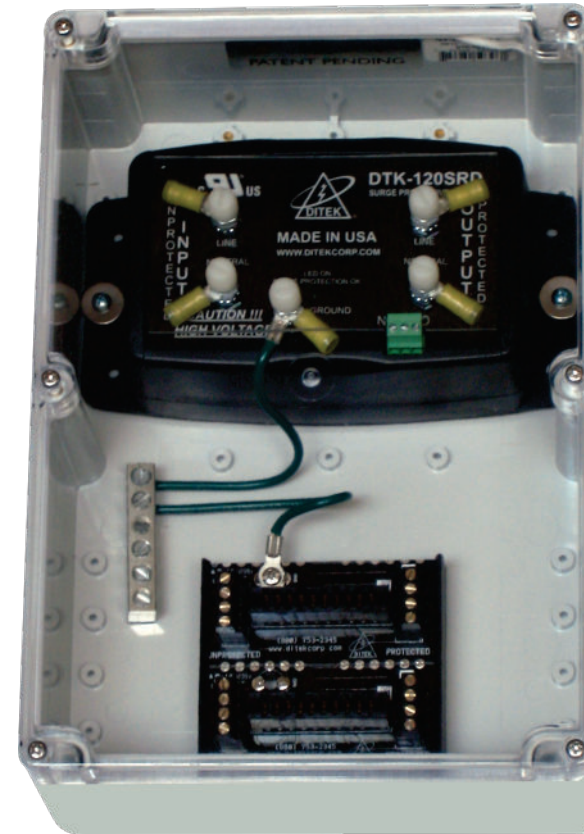

DITEK CORPORATION

One DITEK Center
1720 Starkey Road
Largo, FL 33771

Sales: 1-800-753-2345

Technical Support: 1-888-472-6100

DITEK TSS2 (Total Surge Solution)

System Overview

TSS2 (Total Surge Solution)

The TSS2 is an integrated surge protection solution for alarm panels. This device provides transient voltage surge protection for two pairs of communication circuits, up to two pairs of initiating circuits, notifying, or signaling circuits, and AC power protection. This product also features field replaceable modules and an edge card connection circuit that shields the AC power circuit from the loop and communication circuits.

Installation

Cabinet

Caution: This installation should be performed by a licensed electrician.

Note: Install this device between the field wiring and the alarm panel.

Disconnect system power and loop circuits before beginning installation.

1. Locate an appropriate area for the cabinet near the alarm panel to be protected.
2. Position the TSS cabinet on the finished wall surface and fasten the cabinet to the wall.
3. Remove the appropriate knockouts from the cabinet to facilitate the routing of the field wiring and alarm panel supply wiring. Make sure the field wiring and the protected wiring to the alarm panel occupy separate conduit feeds.

Optional: Use a Nema 4X rated connector if you wish to maintain the NEMA 4X rating of the enclosure.

4. Pull the field wiring and the alarm panel supply wiring through the appropriate knockouts on the cabinet. Make sure to route the AC power wires separately from the loop circuit wires.

Note: When using the TSS2, the enclosure can be mounted directly onto a panel, frame or other mounting surface through corner mounting holes. Corner hole mounting is required to maintain the NEMA 4X rating.

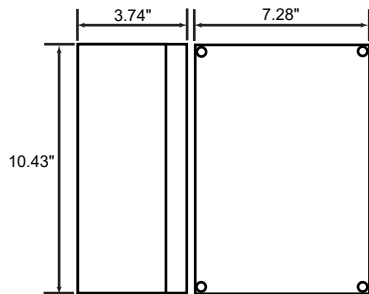

TSS2

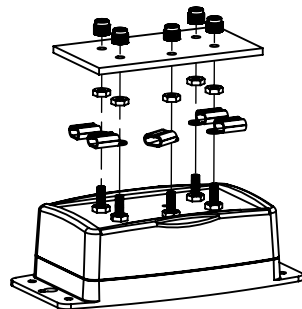

191520 INT-100088-001 Rev 6

DITEK CORPORATION

One DITEK Center 1720 Starkey Road Largo, FL 33771

1-800-753-2345

www.ditekcorp.com

DTK-120SRD (120V Series Surge Protector)

Warning !! Turn power off at the main circuit breaker panel.

Note: Connect this device in series between the AC power supply wiring and the alarm panel AC inputs.

1. Crimp the supplied ring terminals to the connection wires.
2. Connect the Ground (green or bare) supply wire to the ground buss on the back plane. The GROUND on the DTK-120SRD has been factory pre-wired. It is not necessary to make any additional ground connections.
3. Connect the Neutral (white) supply wire to the NEUTRAL terminal on the Input side.
4. Connect the Phase (black) supply wire to the LINE terminal on the Input side.
5. Connect the Ground, Neutral and Phase wires from the Output side to the alarm panel AC inputs.
6. After all connections have been made and metal nuts have been torqued to 10 inch pounds, install the plastic protective cover and fasten with the included nylon nuts until snug.

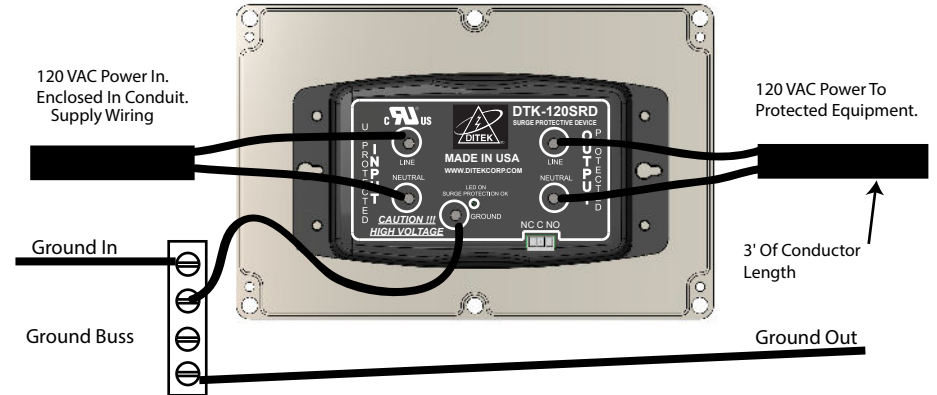

DRY CONTACT CIRCUIT INFORMATION

