

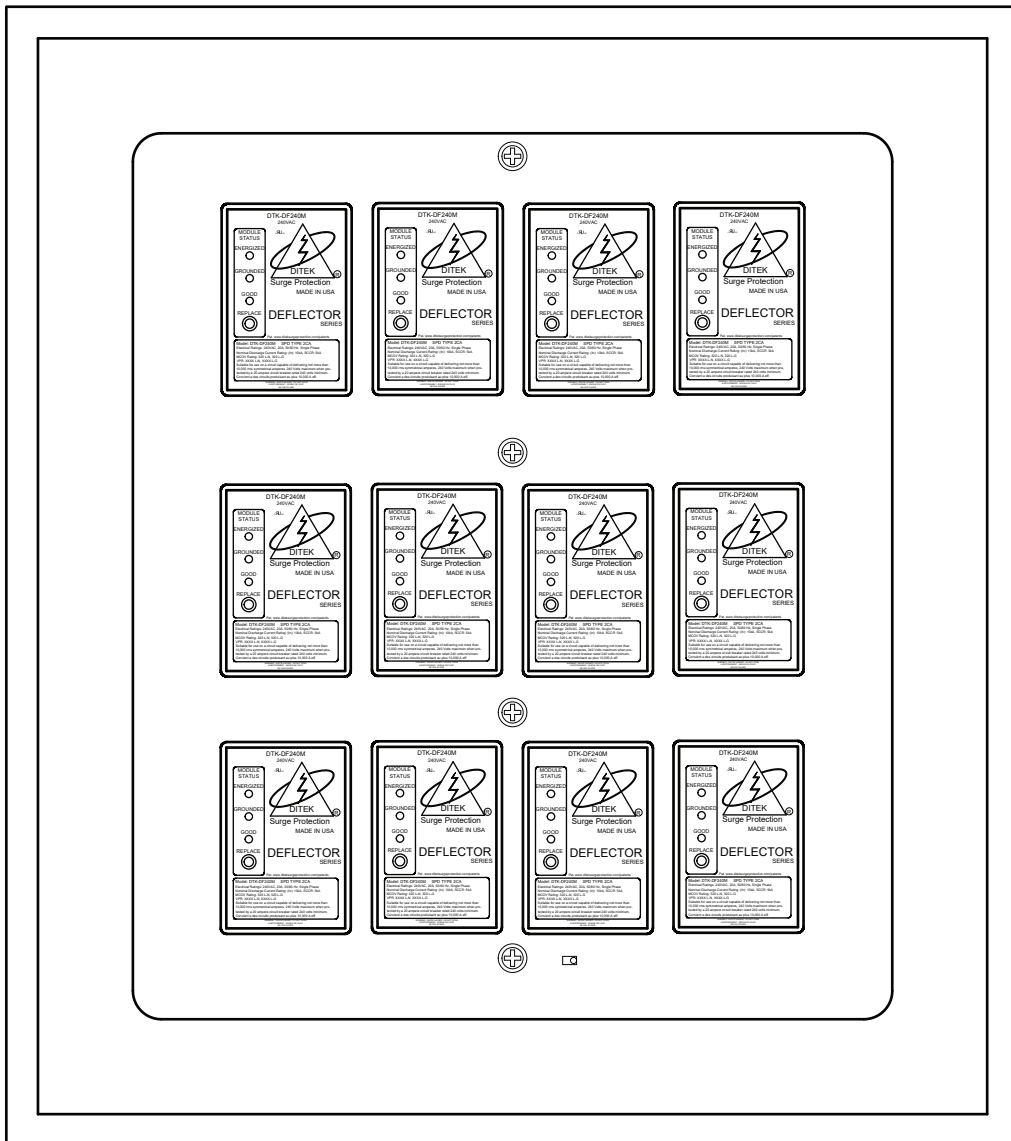

# DTK-DF240S12

## User Guide



### DITEK CORPORATION

One DITEK Center 1720 Starkey Road Largo, FL 33771  
1-800-753-2345 [www.diteksurgeprotection.com](http://www.diteksurgeprotection.com)

# DTK-DF240S12

## (Mounting Dimensions)

Use appropriately sized conduit fittings and conduit. (Not Included)

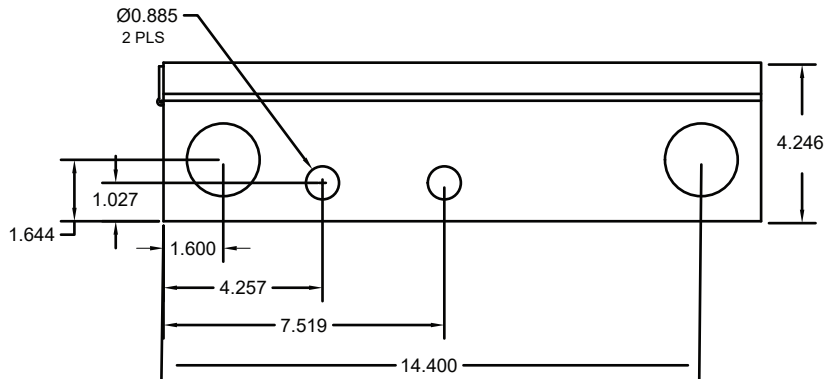
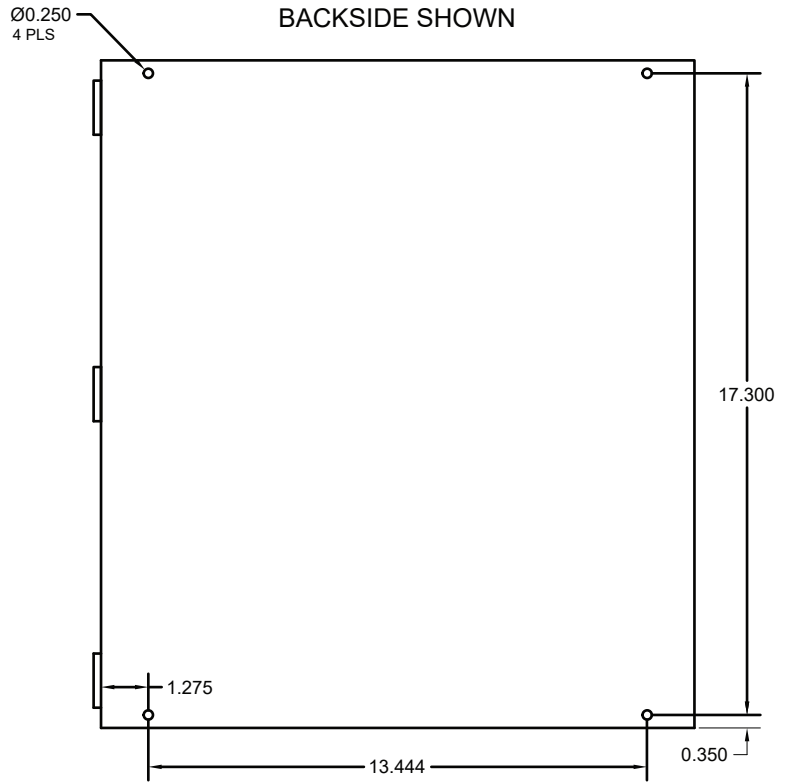
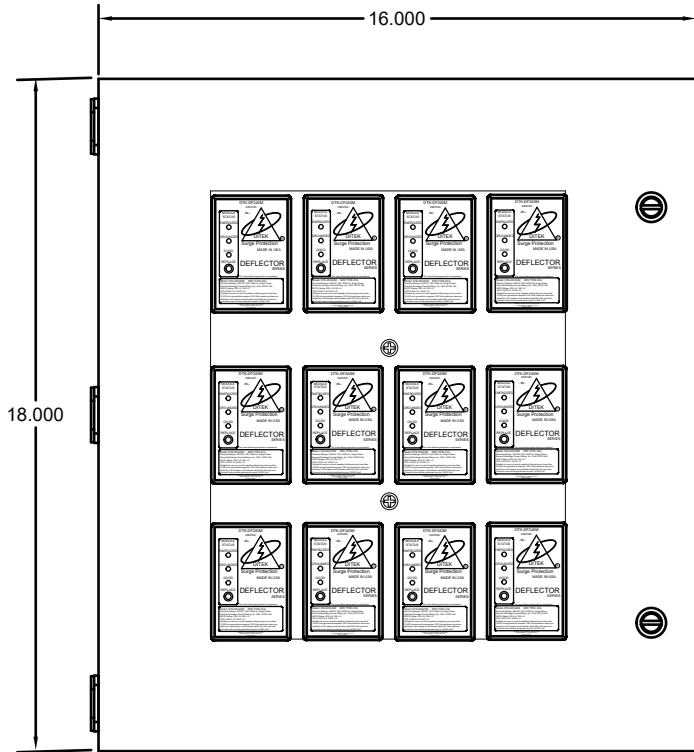
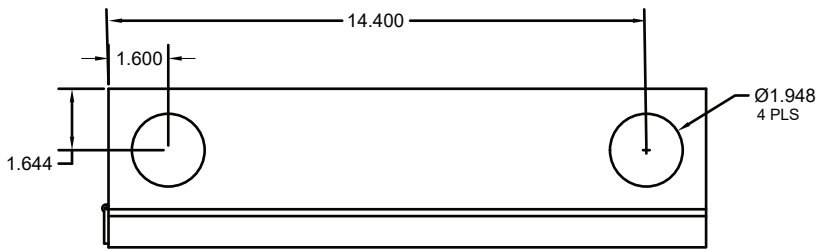

DTK-DF240S12  
(Wiring Diagram)

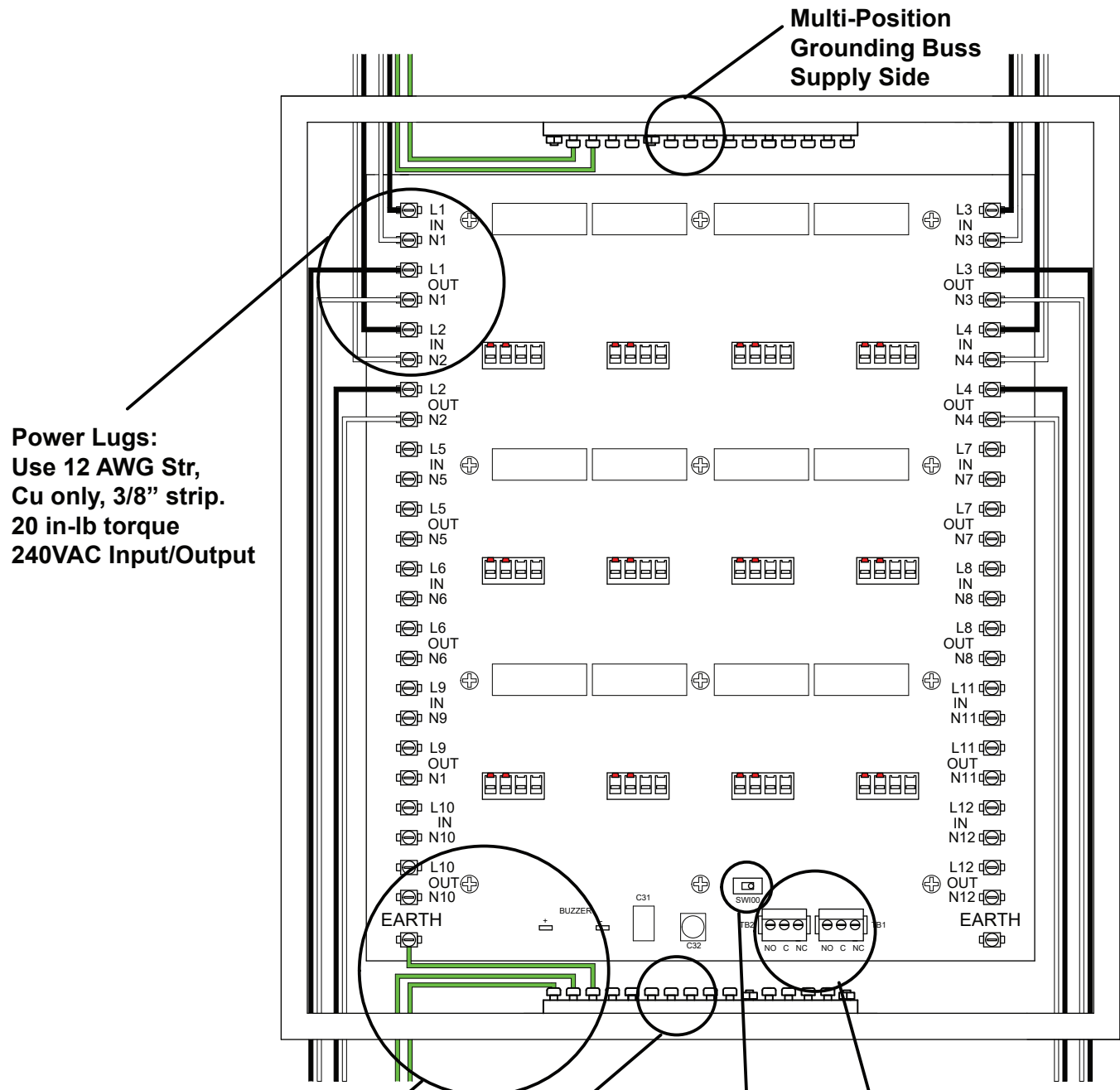

**Power Lugs:**  
Use 12 AWG Str,  
Cu only, 3/8" strip.  
20 in-lb torque  
240VAC Input/Output

**EARTH Grounding Point:**  
This grounds the board  
to the chassis.  
Use 12 AWG Str,  
Cu only, 3/8" strip.  
20 in-lb torque

**Multi-Position  
Grounding Buss  
Load Side**

**Toggle Switch:**  
Center = Normal  
Bypass = Left or Right

**DRY CONTACT CIRCUIT INFORMATION**

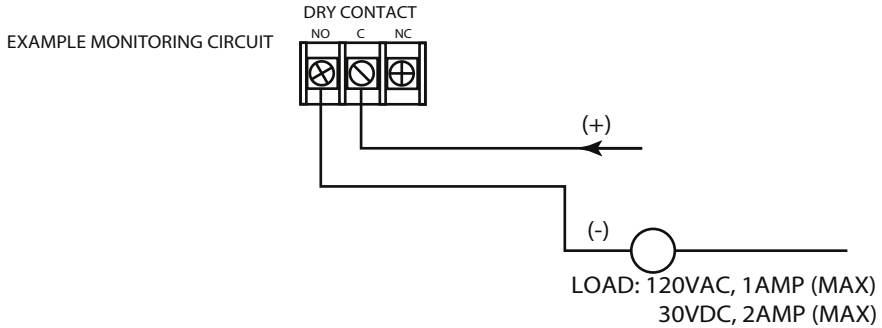

## DTK-DF240S12 (12 Circuit 240VAC 20A Series Surge Protective Device)

**CAUTION: Risk of Electric Shock-Only intended for installation in accordance with National Electric Code, ANSI/NFPA-70, Article 398.**

**Warning:** Turn power off at the main circuit breaker panel before beginning install.

Note: Connect this device in series between the 240VAC power supply and the loads that require protection. Use 12 AWG Stranded, Cu only conductors with a 3/8" strip length when terminating the wires at the power lugs. The conductors used to connect the SPD, to the supply or buss and to ground, shall not be any longer than necessary and shall avoid unnecessary bends.

1. Remove (4) screws securing the safety barrier, save screws.
2. Remove safety barrier.
3. Connect a Ground (green or bare conductor) from the EARTH terminal at the bottom of the board to the multi-position grounding buss located at the bottom of the enclosure.
4. Connect the Grounds, (green or bare conductors) from the distribution panel to the multi-position grounding buss located at the top of the enclosure.
5. Connect the Neutral (white conductor) supply wire from the distribution panel to the NEUTRAL terminal at the **N1 IN** lug.
6. Connect the Phase (black conductor) supply wire from the distribution panel to the Phase terminal at the **L1 IN** lug.

Note: Circuit 1 must be connected first. The diagnostic circuits get their power from this input.

7. Connect the Neutral (white conductor) for the connected load to the **N1 OUT** lug.
8. Connect the Phase (black conductor) for the connected load to the **L1 OUT** lug.
9. Connect the Grounds, (green or bare conductors) for the connected loads to the multi-position grounding buss located at the bottom of the enclosure.
10. Repeat the above steps for circuits 2 through 12

Note: Tightening torque for the 240VAC power connections is 20 in-lb.

11. Use 1-1/2" conduit fittings for the AC circuits and a 1/2" conduit fitting for dry contacts.
12. After all connections have been made and no hazards exist, replace safety barrier and secure with screws.
13. Insert DTK-DF240M surge modules, starting with circuit 1, then restore power.

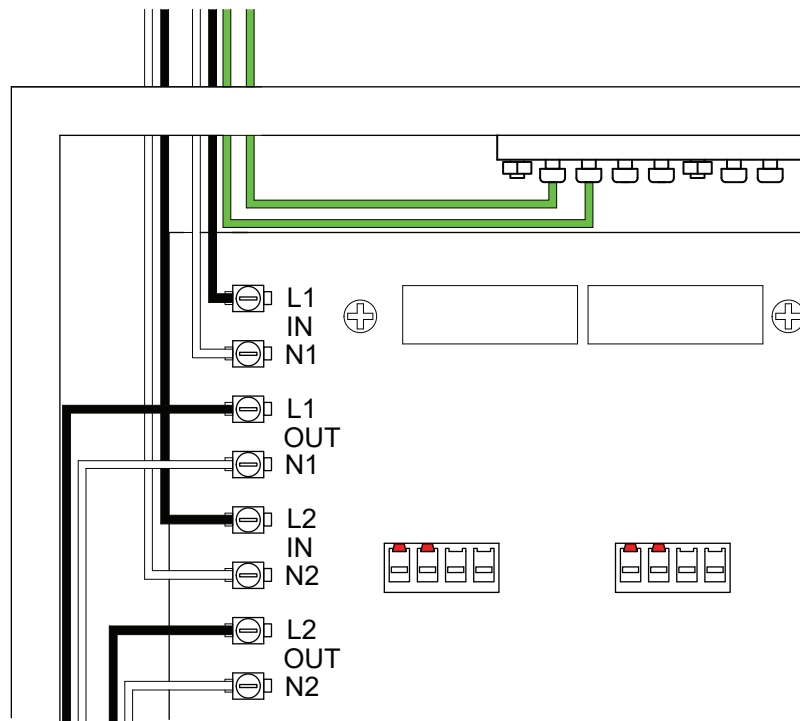



# DTK-DF240M (Surge Module)

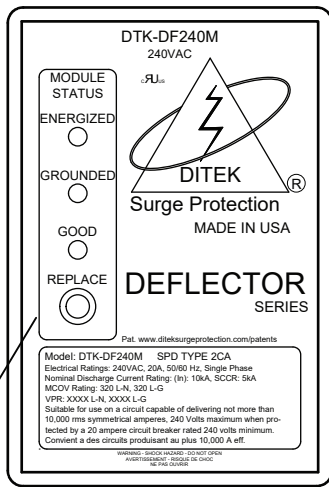

Front

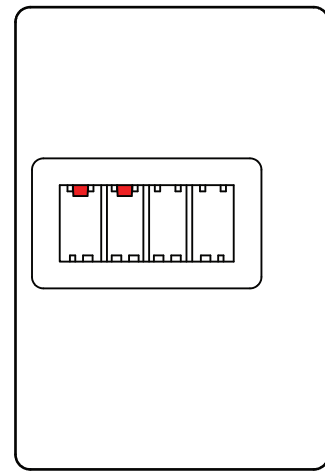

Back

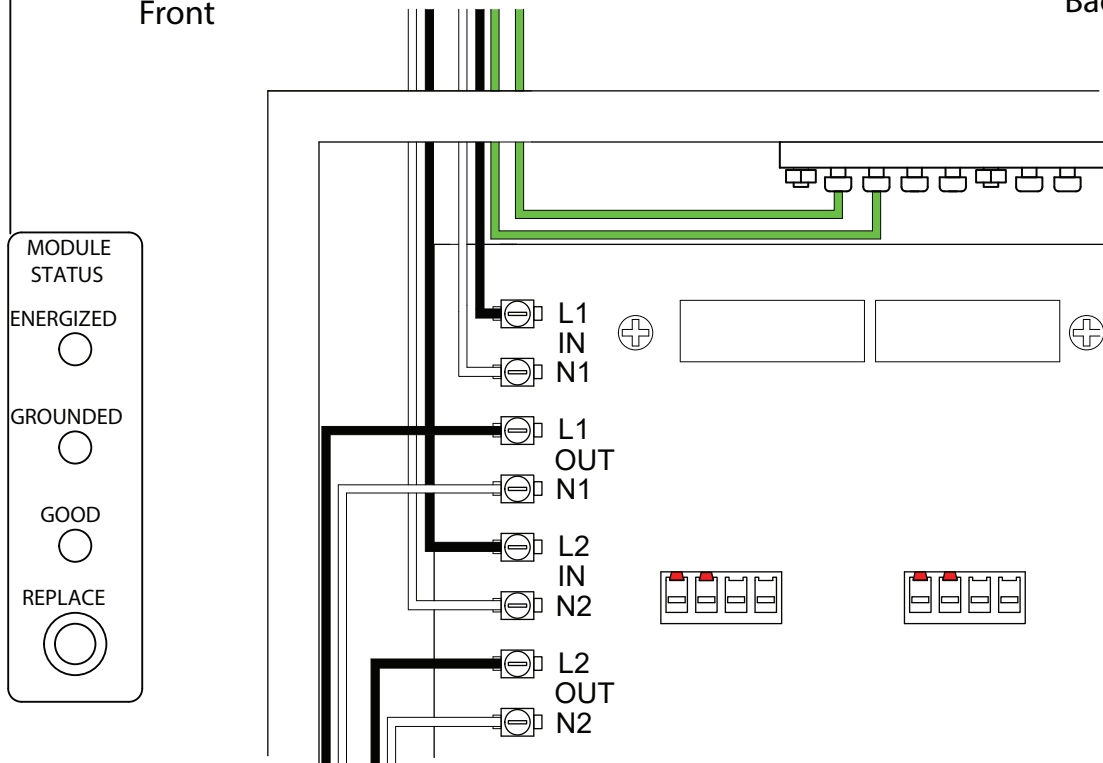

The DTK-DF240S12 is a series connected Surge Protective Device, for 12 individual loads, with a replaceable surge module for each load. The LED indicators on the top face of the DTK-DF240M surge module provide power, ground and surge module health status. When the DTK-DF240M surge module has gone end of life, the large “REPLACE” RED LED will illuminate and the “GOOD” Green LED will turn off. Also, the audible alarm will sound to provide an extra alert to indicate the surge module’s health. To silence the alarm, remove the dead module and replace it with a new, unused module. If a new module is not available, the alarm can be silenced by moving the toggle switch into BYPASS mode. When a new DTK-DF240M surge module is installed, this toggle switch must be moved to the center, or the “NORMAL” position before installing the new module. The red polarizing keys insure that the correct voltage module will mate with its corresponding base.

**WARNING:** When the DTK-240M module has gone end of life, or is missing, the base is susceptible to damage from surge energy. Make sure you always have a spare module available. No substitutions shall be permitted.

**THIS PAGE LEFT INTENTIONALLY BLANK**



191624 INT-100187-001 Rev 2

**DITEK CORPORATION**

One DITEK Center 1720 Starkey Road Largo, FL 33771  
1-800-753-2345 [www.diteksurgeprotection.com](http://www.diteksurgeprotection.com)