



DITEK Corporation
ONE DITEK CENTER
1720 Starkey Road
Largo, FL 33771

INSTALL INSTRUCTIONS

DTK-PVP-TPV

This Surge Protective Device (SPD) is a high performance device, designed to provide protection for sensitive electronic loads connected to service panels, fire panels, or where the SPD is directly connected to the electronic device. Maximum protection will only be achieved if the SPD is properly installed. Please read and follow the installation instructions carefully.

NOTICE: This SPD should be installed and grounded, by a licensed contractor, per the applicable requirements of the NEC. These devices are only to be employed on communication loop circuits which have been isolated from the Public Switched Telephone Network.

APPLICATION

Low voltage power and twisted pair video protection. For analog Fixed cameras.

This device is intended for indoor use or intended for outdoor use within an enclosure which has been evaluated for the applicable environment.

WIRING INSTRUCTIONS:

Caution: Measure all voltages to insure applied voltage does not exceed the voltage rating of the module. Improper installation voids the warranty.

Pre Install Actions:

This unit must be connected in series with the field wiring and the equipment to be protected.

1. Check the power and video signals before installation to verify correct operation.
2. Power down and disconnect the circuits this device will connect to before beginning installation.
3. Securely mount this unit between the field wiring and the equipment to be protected. Use the double sided tape or two #8 screws (provided).

Note: Allow the surge protector reaction time by providing 3-6 wire feet of conductor length between the DTK-Unit and the equipment to be protected.

Video Protection:

1. Connect the unprotected video feed from the field to the VIDEO IN connector.
2. Connect a minimum 3 foot patch cord from the VIDEO OUT connector to the video input of the equipment to be protected.

Power Protection:

1. Connect the input wiring from the 12V/24V power supply to the UNPROTECTED IN terminals marked 12V/24V PWR.
2. Connect a minimum of 3 feet of supply wires from the PROTECTED OUT terminals marked 12V/24V PWR to the inputs of the equipment to be protected.

Ground Connection:

Connect a minimum #14 AWG wire from the ground connector to the common earth ground. Always have one common ground per system to eliminate the possibility of a differential in ground potentials.

Ground Resistance Rule:

Max ground resistance is 25 Ohms, 5 Ohms or less is optimum.

This cannot be an assumed value and must be measured to assure proper grounding.

Post Install Actions:

After all connections have been made and no hazards exist, restore power.

Check the power and video signals after installation to ensure proper install and no signal distortion.

For further information or technical support, please call 1-888-472-6100.

INSTALLATION



DITEK Corporation
ONE DITEK CENTER
1720 Starkey Road
Largo, FL 33771

INSTALL INSTRUCTIONS

DTK-PVP-TPV

Illustrations Page

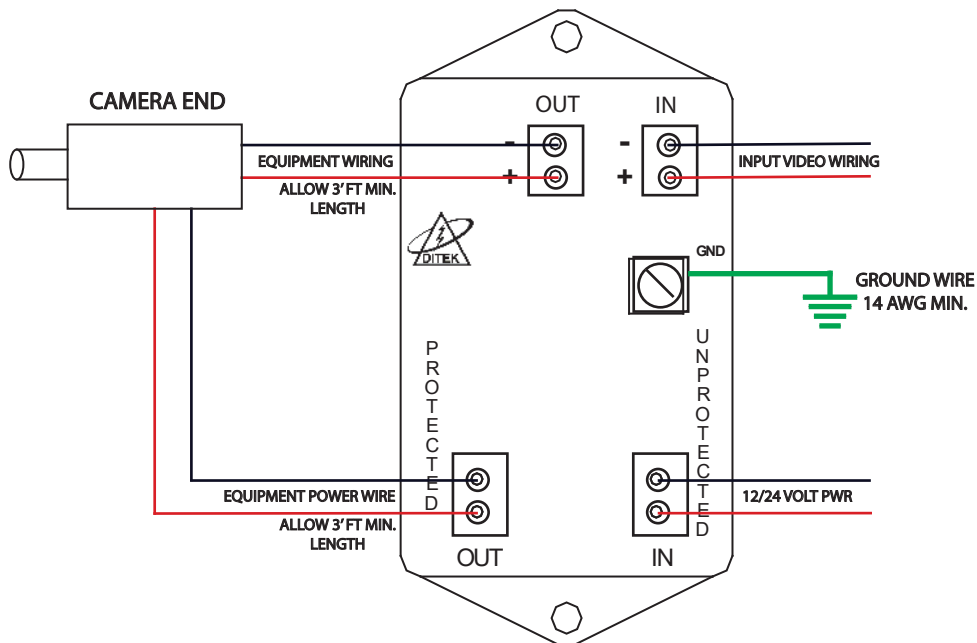
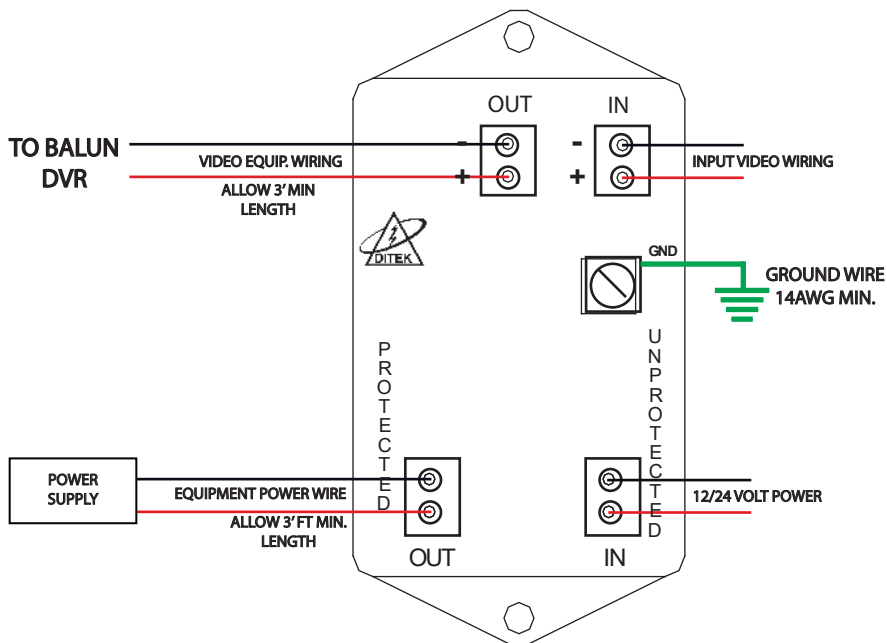

INSTALLATION